

### 前言

「態度、效率、誠信、品質、技術、服務」

本公司以品質第一、技術領先、時代潮流、熱忱完善的服務來服務大眾；更以「以和為貴」、「善待處事」、「精益求精」、「技術創新」為經營理念，促進生活品質。

今後我們將以「世界性、國際性」為目標向前邁進，盼各先進多予指導、批評。

#### FOREWORD

"Attitude, Efficiency, Trustworthiness, Quality, Techniques, Service."  
We offer general public with enthusiastic and sound services that is quality-first and leading in technology. We further upgrade living quality in the concept of "harmony-aware", "treating good", "ever-improving" and "technical innovation". We are now marching toward "being global and international" and welcome your comments.

### 公司設備

為生產世界水準的空壓機，在追求高品質及高效率的理想下，公司廠房設備從CNC車床，床台型強力床、CMC臥(立)式綜合切削機、多軸鑽孔專用機、我們從鑄造及加工製成一手掌控；確保充裕製程控管能力。此外我們更不斷引進自動化設備，為求生產效率及世界競爭力。

#### PRODUCTION FACILITY

In the pursuit of high quality and efficiency in producing world-class air compressors, the Company operates with a wide range of equipment from CNC lathe, heavy-duty machines, to CMC horizontal (vertical) general-purpose cutters and multi-axis drilling machines, with which we have full control of all processes from foundry to machining and ensure of the sound management of the processes. We also incessantly introduce automatic equipment to maintain our productivity and world competitiveness.



## 氣冷皮帶式(往復式)空氣壓縮機系列

### Air-Cooled Piston (Belt) Type Air Compressor Series

氣冷皮帶式空氣壓縮機(亦稱活塞往復式空氣壓縮機)是現今使用最廣泛的壓縮機，係將空氣導入活塞並在氣缸內上下往復運動來壓縮空氣至所要求的工作壓力。

氣冷皮帶式(往復式)空氣壓縮機機體基本構造：  
Air-cooled Piston (Belt) Type Air Compressor Internal Structure

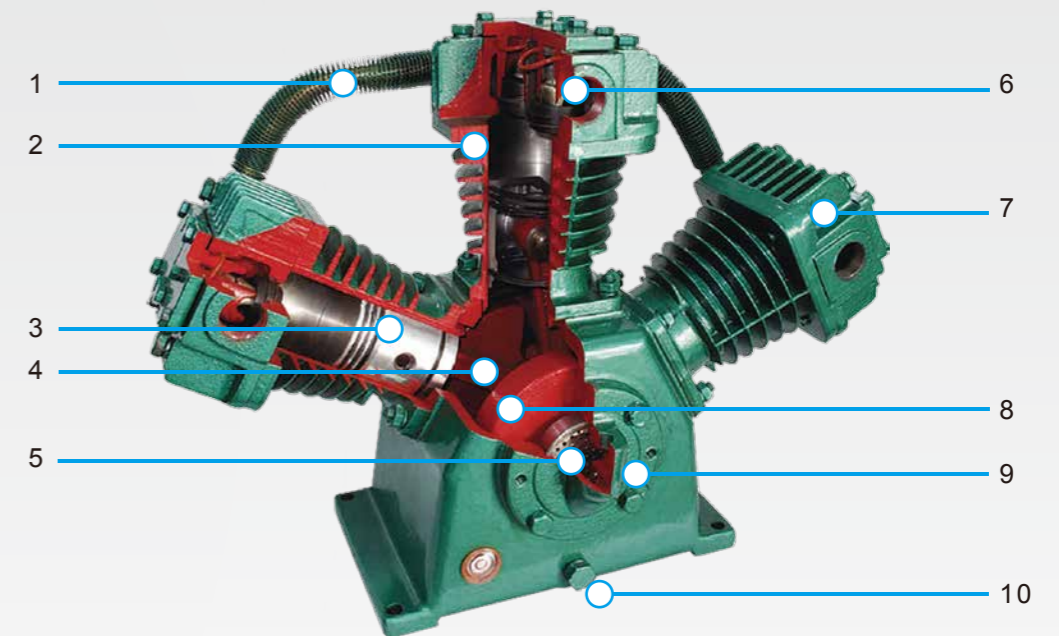

1	散熱銅管	Radiating cooper pipe
2	氣缸	Cylinder
3	活塞、活塞環	Piston、Piston ring
4	連桿	Connecting rod
5	軸承(培林)	Bearing
6	吸氣閥、排氣閥	Suction valve、Exhaust valve
7	氣缸蓋	Cylinder head
8	曲軸	Crankshaft
9	曲軸箱	Crankcase
10	洩油孔	Drip hole